

D9200 Series

Monitor Specifications

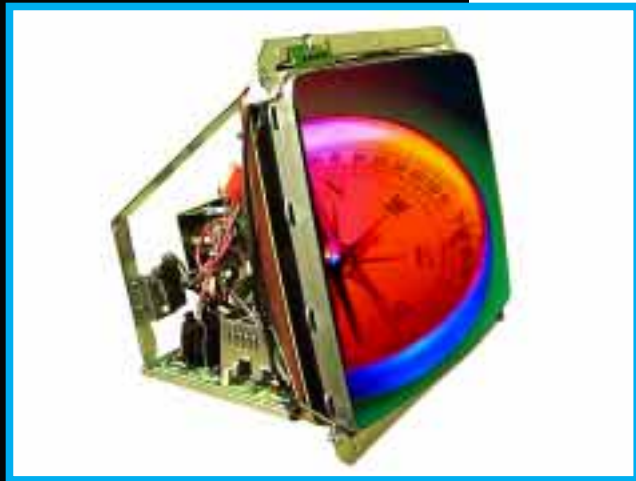

Digital Monitor

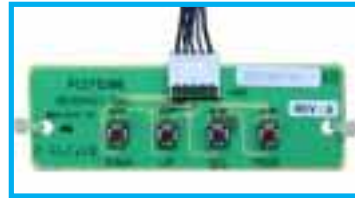

Push Button
Control Board



On-Screen Display

Power Input

- Input voltage: 90-264 VAC, 50-60 Hz; no isolation transformer required
- Maximum power: 150 watts typ.

Resolution

- Graphics modes: CGA: 640 X 200
EGA: 640 X 400
VGA: 640 X 480
- Video bandwidth: 25 MHz typ.

Miscellaneous

- Operating temperature: 0 to 55 degree C.
- Agency compliance: UL6500, CSA, CB (IEC65), DHHS, CE

Specification

- CRT size (diagonal measure): 27", 33"
- Phosphor type: P22
- Color Temperature: 8500°K +/- 500°K
- Dot trio spacing: 0.83 mm (27"); 0.92mm (33")

Input Signals

- Input connector: CGA/EGA: 0.156 center header, VGA: 15 pin D-sub high density male
- Video input impedance.: CGA/EGA: 4.7K Ohm, VGA: 75 Ohm
- Video level: CGA/EGA: 2.2 Vp-p, VGA: 0.7 Vp-p
- Video type: RGB analog
- Sync type: TTL sync; separate or composite, negative or positive
- Sync input impedance: 2.2K Ohm (H sync and V sync)
- Horizontal sync frequency: 15.75 to 31.5 KHz
- Vertical sync frequency: 45 to 90 Hz

Light Output

- 60 Ft-L min. (center block)

Geometry

- Horizontal linearity: +/- 7%
- Vertical linearity: +/- 5%
- Picture size regulation: +/- 2%
- Geometric distortion: +/- 2% max.

User Controls

- I²C bus remote controls: Brightness, contrast, horizontal size, horizontal position, vertical size, vertical position, pin cushion, trapezoid, color temperature, factory setup recall
- Internal controls: Sub-brightness, focus, G2 (screen), raster tilt, HV adjust

D9200 Series

Monitor Specifications

27" Digital Monitor

DIM.	IN.	MM.
A	21.893	556.08
B	20.644	524.36
C	20.644	524.36
D	24.390	619.51
E	16.187	411.15
F	3.292	83.62
G	4.812	122.23
H	9.812	249.23
J	1.812	46.02
K	12.375	314.33
L	4.438	112.73
M	.900	22.86
N	4.250	107.95
P	20.187	512.75

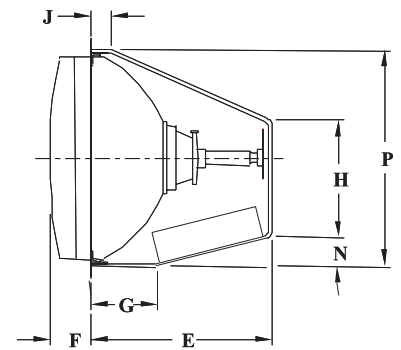
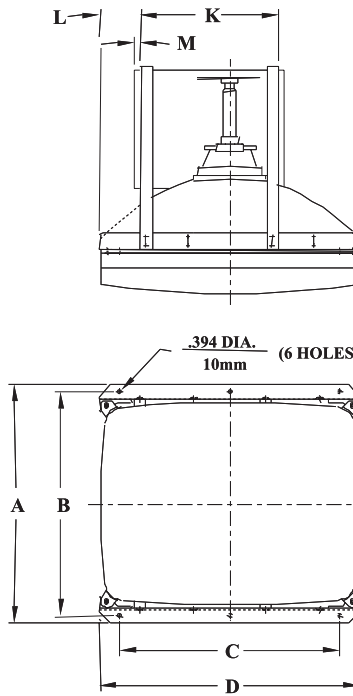

33" Digital Monitor

DIM.	IN.	MM.
A	25.281	642.14
B	24.031	610.39
C	24.031	610.39
D	28.274	718.16
E	18.250	463.55
F	3.292	83.62
G	4.812	122.23
H	9.812	249.23
J	1.812	46.02
K	13.736	348.89
L	5.268	133.81
M	0.900	22.86
N	4.250	107.95
P	23.375	593.73

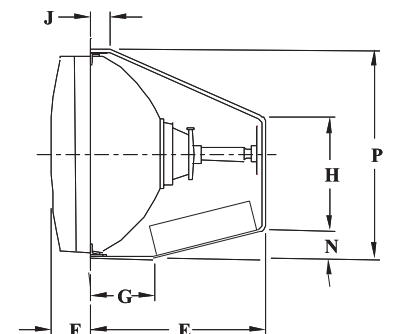
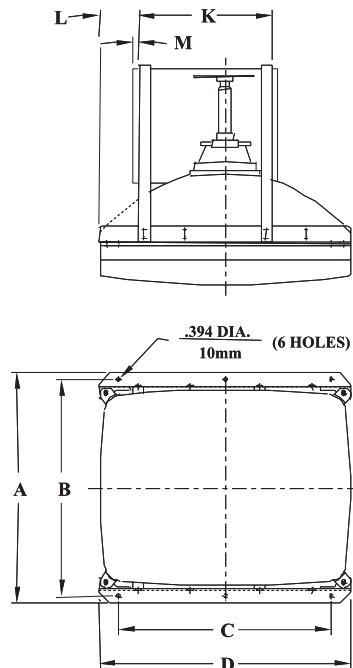

Specifications subject to change without notice.



202 West Parkway Drive
Egg Harbor Twp., NJ 08234
Tel: 609-383-9970 • 800-890-9298
Fax: 609-383-9971
www.wellsgardner.com